

Packaging/food/medicine

20 Liquid Detection in Opaque Container

For non-metal containers. The presence or absence of liquid contents can be easily detected by the Static Volume Proximity type.

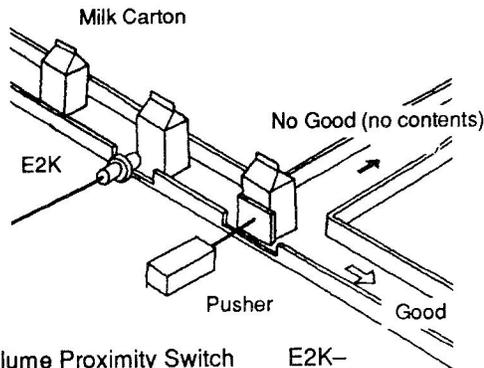

Static Volume Proximity Switch E2K-C25ME1

21 Detection of Label on Medicine Bottle

If bottle has no label, the line is stopped and a buzzer and light are activated. One S3D8 unit can control two lines.

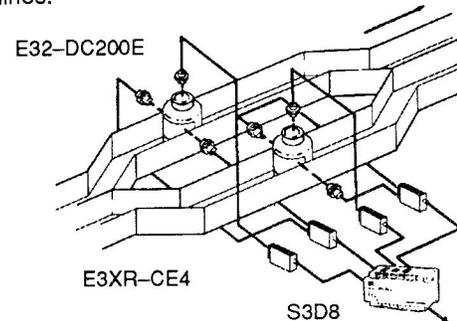

Fiber Unit E32-TC200E/E32-DC200ER2
Amp Unit E3XR
Sensor Controller S3D8

22 Ampule Detection for Small Area

This model is good for small spaces because the fiber can be cut freely. It can detect without needing the sleeve and can be installed anywhere.

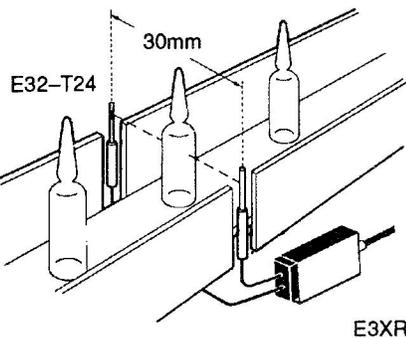

Detection Subject: Glass Ampules

Fiber Unit: E32-T24

Amp Unit: E3XR

23 Inspection of Length of Medicine Packaging

Uses three photoelectric switches to determine the length of the medicine pouch.

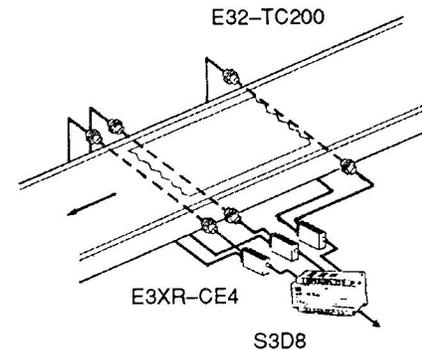

Fiber Unit: E32-TC200
Amp Unit: E3XR

24 Food Packaging Inspection

Detects wrinkles in the food pack. The sensors are set, as in the diagram, so that light is received if the food pack is wrinkled.

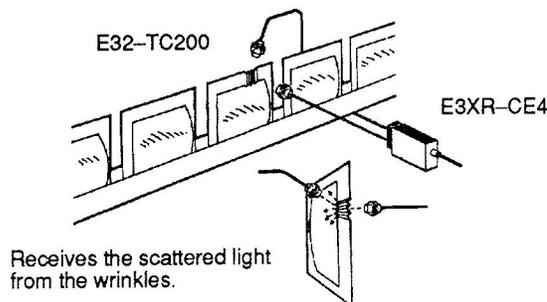

Receives the scattered light from the wrinkles.

Fiber Unit: E32-TC200
Amp Unit: E3XR-CE4

25 Ampule Inspection

The reflector can be attached to a wall, making it convenient and space saving for ampule inspection in narrow places. With the adoption of the MSR function, reliability compares favorably with the transmission type.

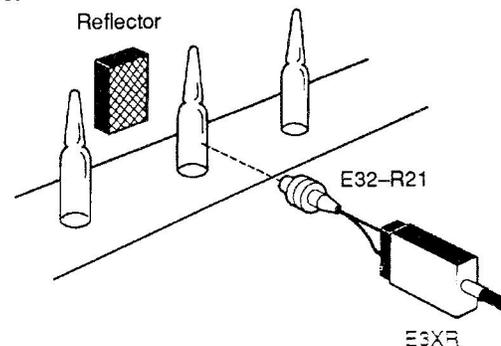

Photoelectric Switch E32-R21 E3XR